

# Multiplexing Wiring

(the control module installed on curb side of lift frame)

**53618-03-M** (2 x 12-way plugs)

(it requires light kit 800084 or 800086)

**Warning:**

- Top of battery needs to be protected. If positive side of battery is accidentally grounded person could be burnt or wiring system can be damaged, or battery gasses could explode causing injuries.
- Disconnect cable from negative battery terminal before starting installation.
- Always wear eye protection and protective clothing when working around hydraulic systems.
- Remove jewelry and objects that might conduct electricity while working on power units.
- Fluid under pressure can pierce the skin and enter the bloodstream causing death or serious injury.
- Hydraulic hoses and electrical cables (harnesses) must be tied and routed safely to avoid any damage and pinching (away from hot places, sharp objects etc.).
- When drilling mounting holes or using self-tapping screws in the engine compartment, ensure to check the mounting location for any wires, hoses other obstructions that could be damaged during installation.

**Installation instructions**

**Note: Apply dielectric grease to all connections to prevent corrosion.**

1. Install MPX modular box as shown in the next page on curb side of lift frame.
  - **If plow light harness has rubber plugs, 2 x 421061-02 light harness must be ordered to continue with installation.**
2. Install the 2 x 421061-02 light harnesses inside of the light housing. Ensure that there is no rust on any connections.

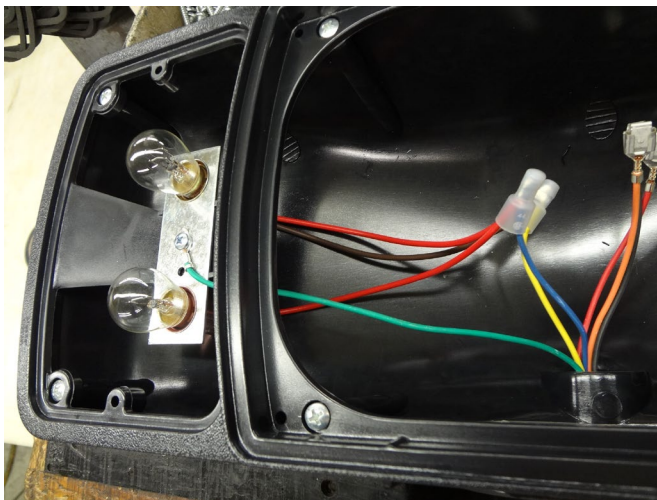

## 53804-MPX

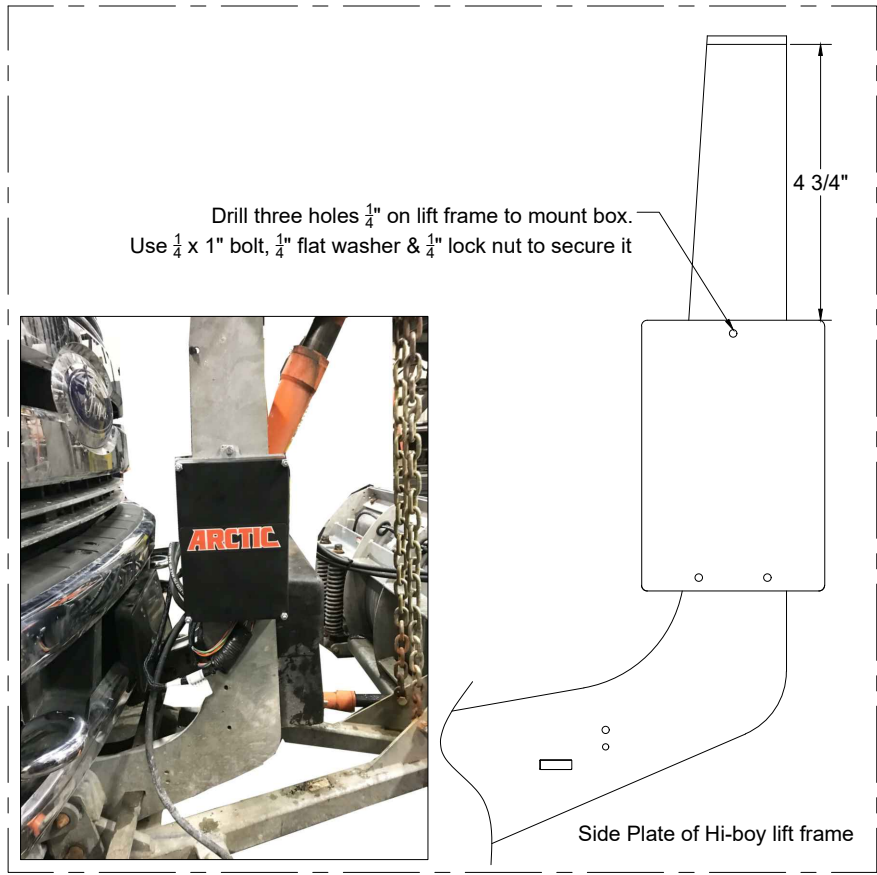
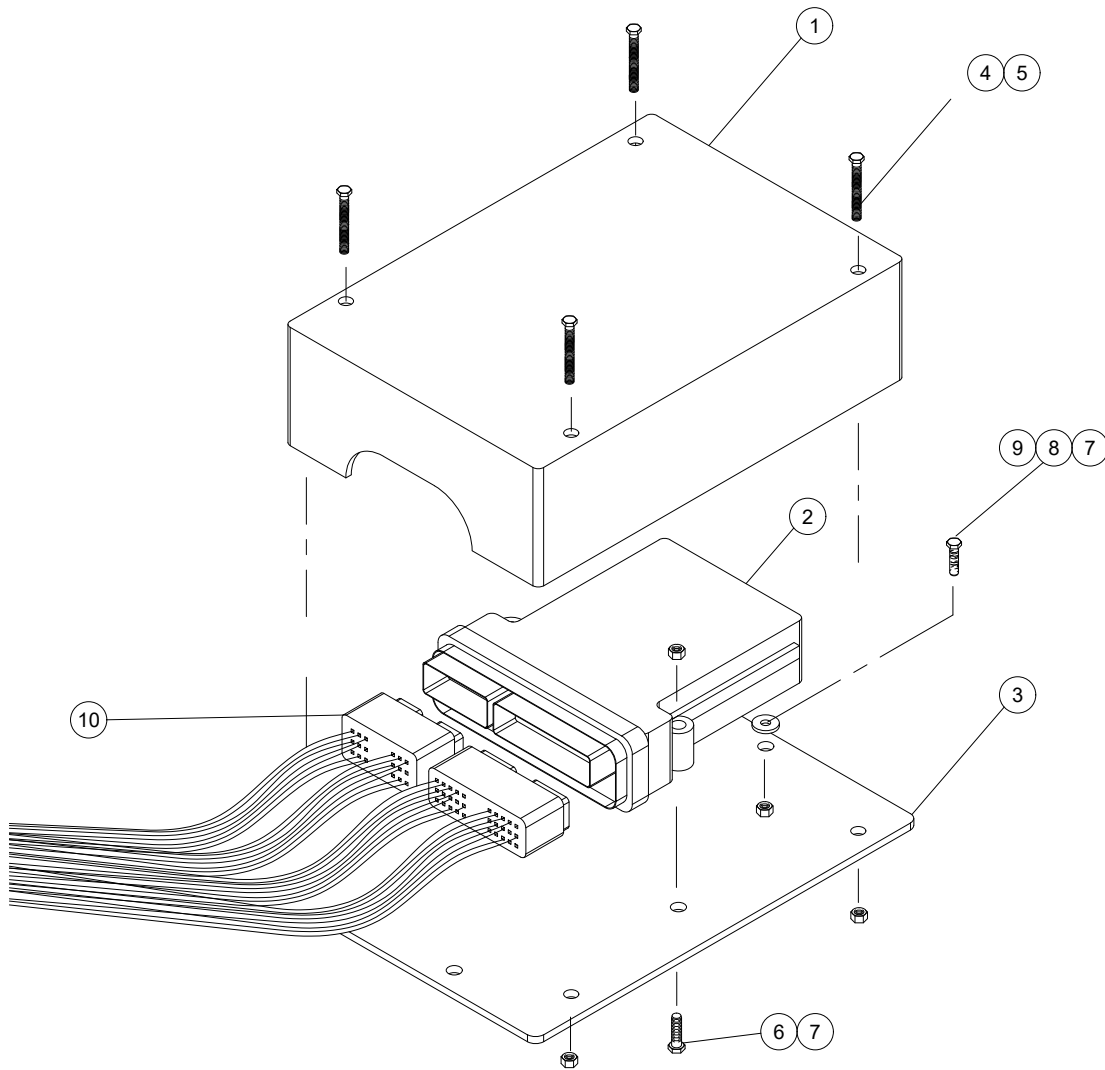

10	53627-MPX	1	MPX Lift frame harness
9	HH-00341-002	3	1/4" Flatwasher
8	HH-00293-006	3	1/4 - 20 x 1 HHCS
7	HH-00340-901	5	1/4 Locknut
6	HH-00012-067	2	1/4 - 20 x 1.5 Flat head Machine Screw
5	HH-00340-020	4	#10 Locknut
4	HH-00360-104	4	#10-24 x 3 Round Machine Screw
3	53718-POLY	1	MPX Poly Mounting Plate
2	800080-MPX	1	MPX Modular box
1	53660-B	1	Plastic Enclosure box for MPX module
Sr No	Part #	Qty	Description
53804-MPX			

- Secure the light harness as shown below. Install the lift frame harness (24) in the pump plate and secure it to the pump plate at the back. (if applicable)

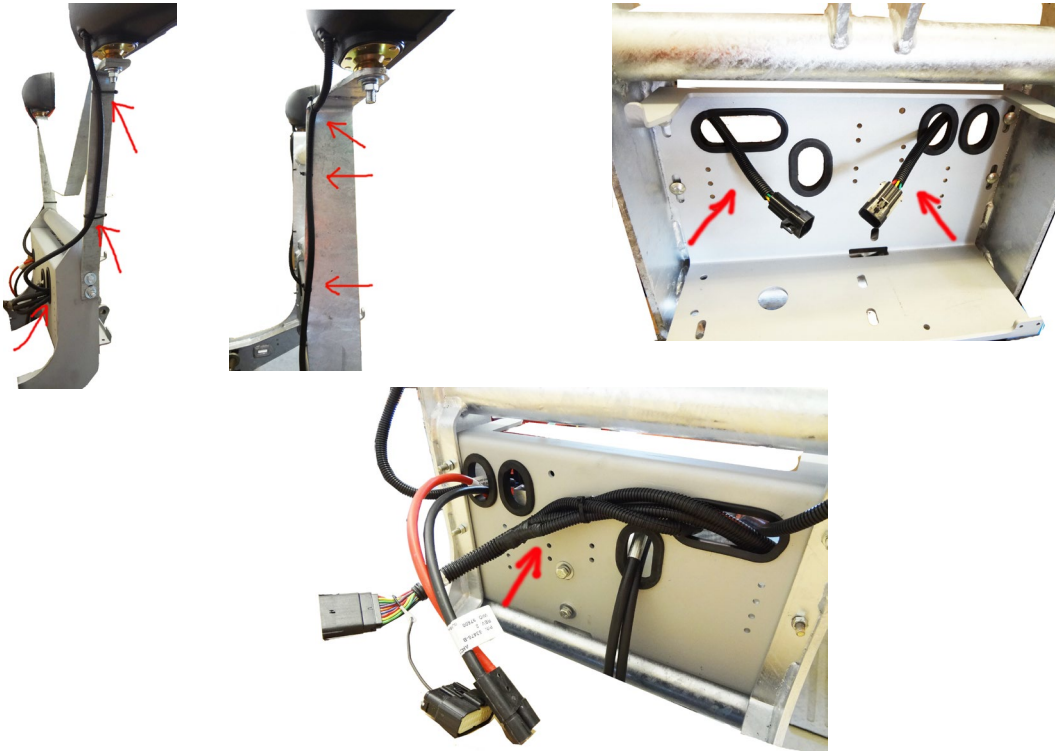

- Plug the light harnesses to the lift frame harness (24) and secure them under the pump cover. (if applicable)  
Attach the power unit leads from the lift frame harness to the coils as per instructions. Ensure that there is no rust on any connections. (see drawings below)

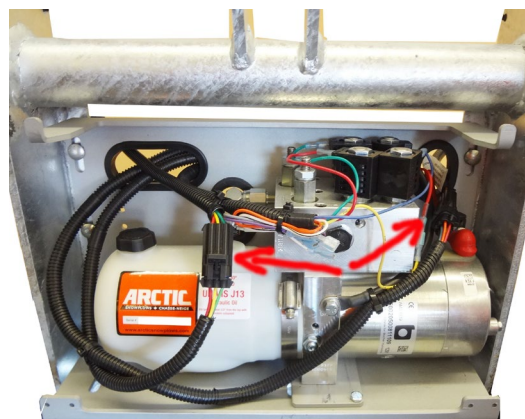

- Mount a solenoid to metal surface, bend bracket if necessary.

NOTE: Solenoid must be well grounded in order to function properly.

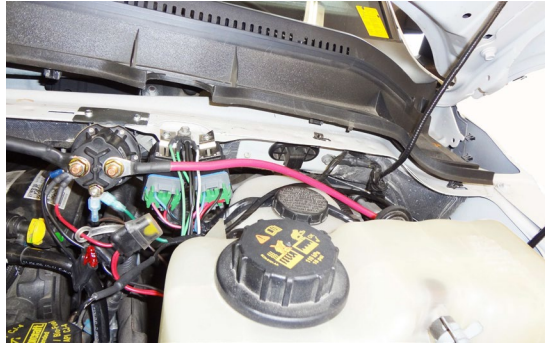

6. Install power cables as shown on the drawing below.
7. For the controller harness (2) locate a pass-through hole in the firewall near the driver's side of the truck. Route the harness through the hole in firewall and secure it under the dash and it should be attached to control station.
8. Connect all wires as shown on the drawing below.
9. Neatly secure all excess cables and wires using tie straps.

Note: Ensure all cables are properly protected from any sharp edges or hot or moving parts!!

Installation of Vehicle Harness RED/WHITE (ignition) wire:

Connect the RED/WHITE wire to a "keyed" 12V+ ignition source. Note: This 12V+ source should only be active when the key is in the ON position. Failure to wire to a "keyed" source can allow a condition to occur causing the battery to drain. This will also prevent operation of the plow without the vehicles key being on.

To find a "keyed" 12V+ ignition source, consult the fuse panel section of the vehicles owner's manual. Look for a fuse labeled ACC/IGN or ACC (Accessory). Remove the fuse, apply the fuse tap as shown below and reinstall the fuse. The RED/WHITE ignition wire can now be plugged to the ¼" fast-on tab.

Note: Check to make sure that the snowplow control ONLY has power when the vehicle ignition switch is ON.

If NO accessory fuse is available, a test light may have to be used to determine if power to a certain fuse (or any other power source) is "switched / keyed" or not.

Note: The RED/WHITE ignition wire is equipped with its own 10-amp fuse, so it can be tapped to any size fuse (10 or above). Do not use two taps on the same fuse.

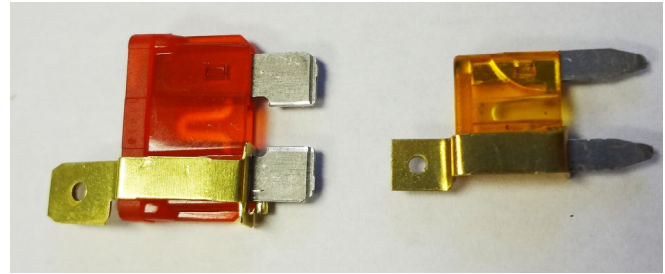
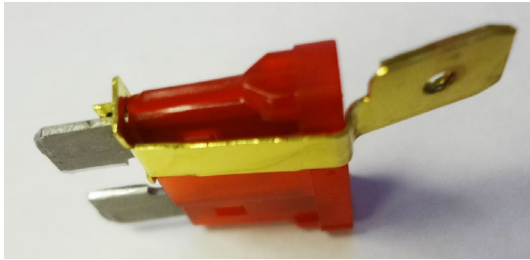

## Lighting System Procedure

**To avoid corrosion, extend the life of the control module & ensure proper plow functionality keep all connectors well-greased with dielectric grease.**

### Basic Lighting Transfer Overview:

To transfer the lights from the vehicles headlights to the plow lights, the Control Module Electrical System installed on your vehicle must see or read four things.

- 1.) The vehicles ignition is turned ON.
- 2.) The vehicles headlight switch is turned ON.
- 3.) The plow is plugged in (by the vehicles grill).

Note: Keep in mind that turning the vehicles ignition OFF, acts as a RESET for the lighting system.

Below is a set of two conditions that may help to better explain the transfer of lights from vehicle to plow:

**\*\*When the vehicles ignition is turned OFF, the entire snowplow system is OFF. (Note: If this is not correct, see the plows installation instructions for proper plow installation).**

**Condition #1:** The vehicle's ignition is turned ON; the plow is NOT attached (and NOT plugged in) and the plow controller is OFF (or not plugged in). When turning ON the vehicle's headlight switch, the vehicles headlights will turn ON.

**Condition #2:** The vehicles ignition is turned ON; the plow is attached (and plugged in) and the plow controller is OFF (or not plugged in). When turning ON the vehicle's headlight switch, the plow headlights will turn ON.

53618-03-M Multiplexing wiring			
	Part#	Description	Quantity
1	53804-MPX	MPX Module Assembly (c/w 800080-MPX, 53627-MPX)	1
2	53625-MPX	MPX Controller Harness	1
3	53614-N	1/4" Fuse Tab	1
4	53615-N	3/16" Fuse Tab	1
5	761321	3/16" Spade Connector	1
6	53541-N	6in Cable ties	10
7	53625-05-N	Low profile fuse holder	1
8	53625-09-N	Low profile Mini 10 Amp fuse	1
9	53625-07-N	Micro dual fuse holder	1
10	53625-08-N	Micro 10 Amp fuse	1

Arctic Equipment Manufacturing Corporation reserves the right under its product improvement policy to change construction or design details and furnish equipment when so altered without reference to illustrations or specifications used.

## Truck Side

## Plow Side

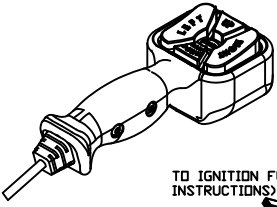

MULTIPLEXING CONTROLLERS

- 53282-MPX (53647-MPX JOYSTICK) STRAIGHT BLADE
- 53326-MPX (53648-MPX JOYSTICK) V BLADE
- 53495-MPX WING BLADE

TO IGNITION FUSE (SEE INSTRUCTIONS)

TO CONTROLLER IN THE CAB (DRILL 1/4" HOLE IN THE FIREWALL)

TO GROUND BATTERY (-) (-) BLACK TO BATTERY (+) RED TO BATTERY

TO SOLENOID

53625-MPX

When the plow is not attached to the truck, plug connectors to each other to avoid corrosion.

TO GROUND BATTERY (-) (-) TO BATTERY (+)

To driver side truck light

LIGHT ADAPTER

Longer side to connected to curb side truck light

To curb side truck light

Note: On some trucks it is required to attach grey wire to the park/run light, the violet wire to the driver side turn and the pink wire to the curb side turn.

Apply dielectric grease to each relay - terminals

To avoid corrosion and extend the life of the Control module, keep connectors well-greased with dielectric grease.

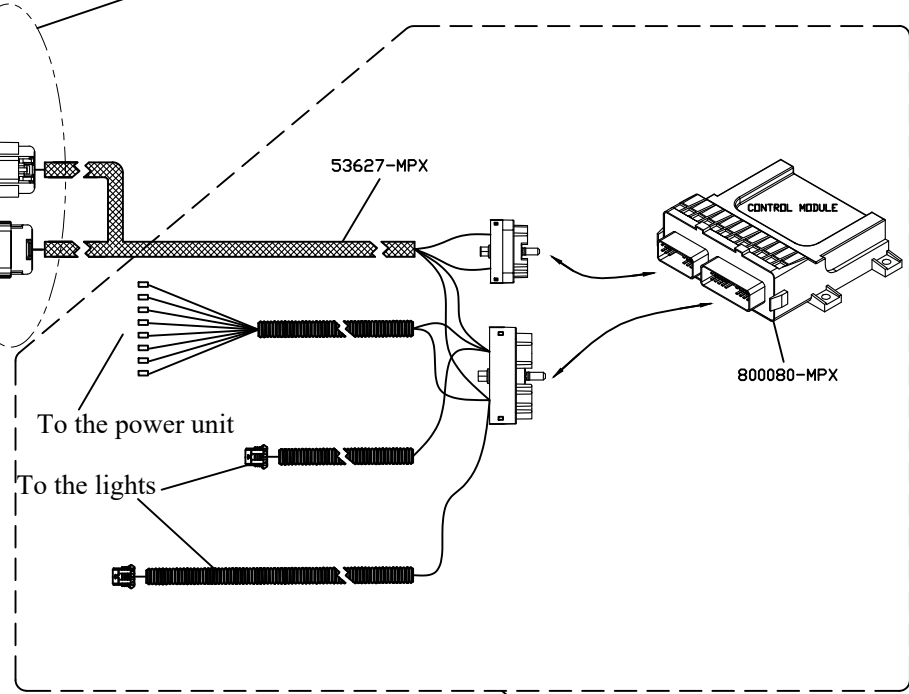

53627-MPX

800080-MPX

To the power unit

To the lights

53804-MPX (BOX ASSEMBLY)



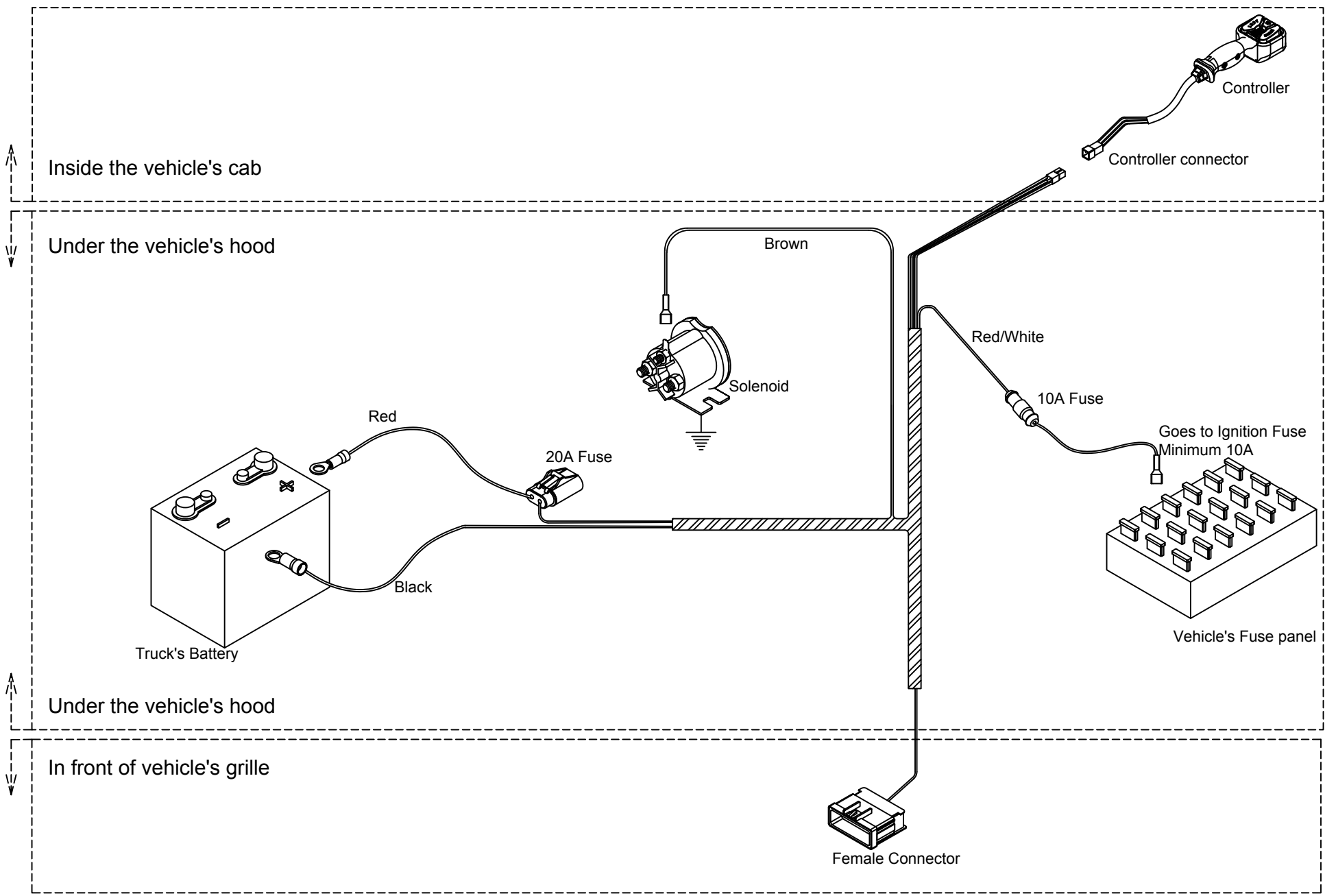

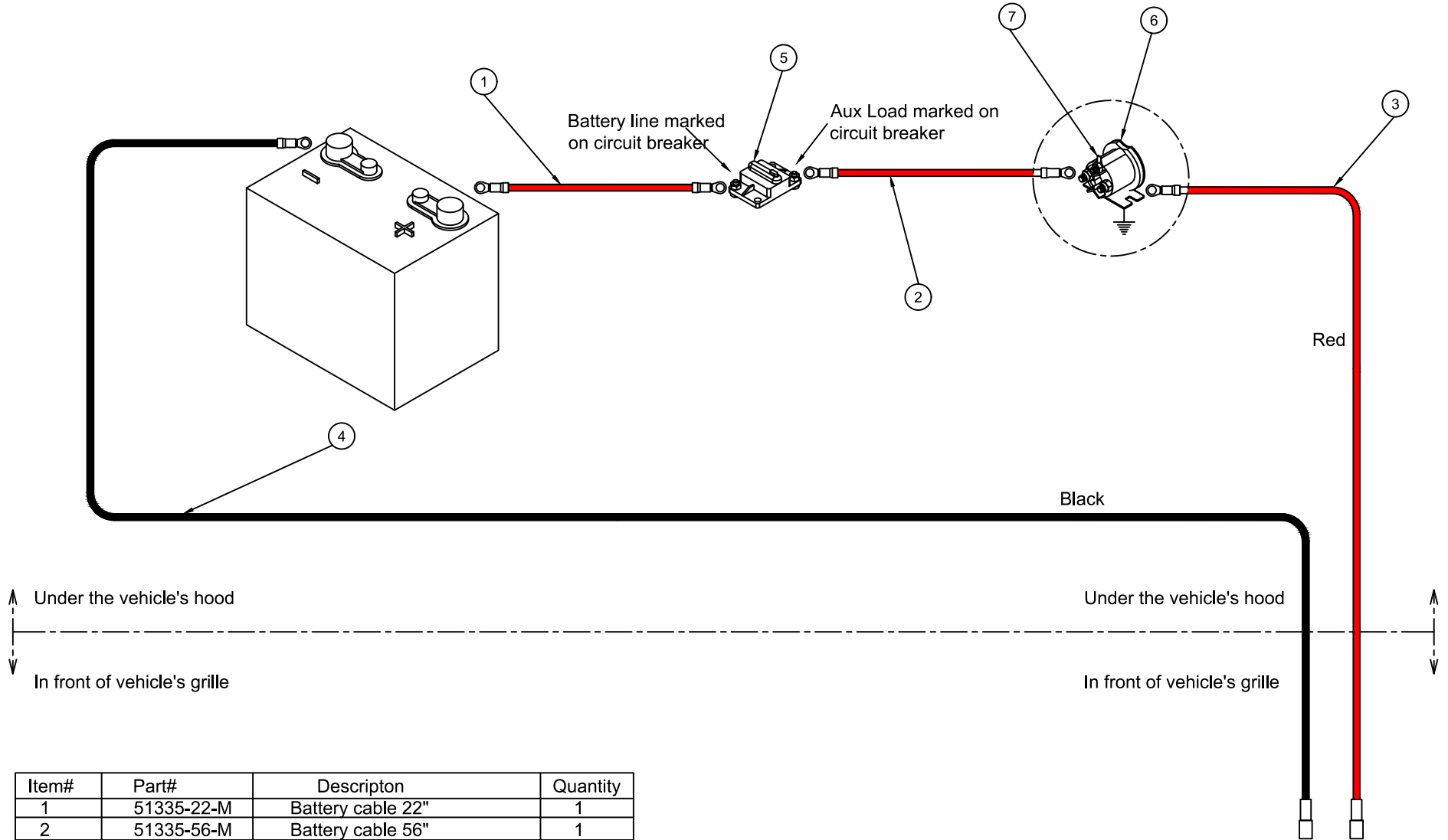

Item#	Part#	Description	Quantity
1	51335-22-M	Battery cable 22"	1
2	51335-56-M	Battery cable 56"	1
3	53478-B	90" Power cable	1
4	53477-B	90" Ground cable	1
5	53608-N	135 amps circuit breaker	1
6	FP17757	Solenoid	1
7	FP3414	#10 Blade terminal (Solenoid)	1



Installed inside plastic enclosure (on side of lift frame)

- Note:
- Use  $\frac{1}{4}$ " screw driver to tighten the plug into the box.
  - Apply torque of 15-20 IN LBS
  - Do not overtighten

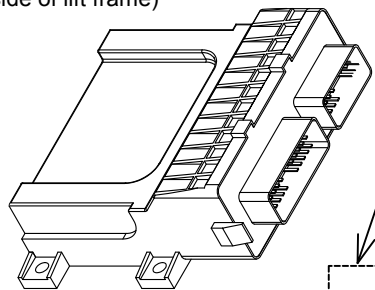

Installation to be done inside the power unit cover

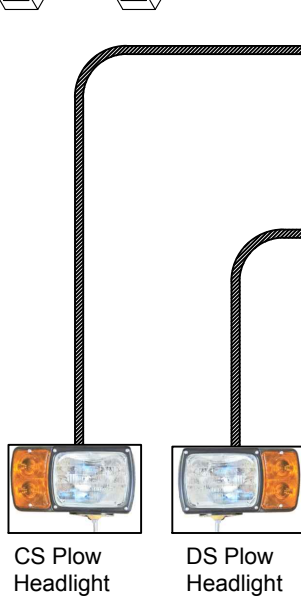

CS Plow Headlight

DS Plow Headlight

Straight Blade		V Blade		Wing Blade	
Valve	Wire	Valve	Wire	Valve	Wire
A	Green	A1	Gray	A	White/Black
B	Yellow	A2	Green	B	Blue
C	Blue	B	Orange	C	Green
D	Red	C	Blue	D	Yellow
		D1	Purple	E	Red
		D2	Red	F	Orange
		E	Yellow	G	Gray
				H	Purple

Unused wires should be tied together

To power unit coils

On the plow

In front of vehicle's grille



Plugs together when not in use A (Apply grease)

On the plow

In front of vehicle's grille

LEGEND

DS - Driver Side  
CS - Curb Side